

JBL2500

JBL2600

JBL2800

JBL3800

JBL4800



JBL SERIES LOUDSPEAKERS INSTRUCTION MANUAL



Introduction

Congratulations on choosing JBL loudspeakers. Their highly accurate, uncolored and balanced sound character will greatly increase your enjoyment of recorded music. JBL speakers are built with careful attention to detail, using only the highest quality materials. They will provide many years of excellent performance.

The JBL Series is the result of concentrated efforts to combine traditional JBL performance values with elegant contemporary appearance at affordable prices. Some of the engineering features of the JBL Series are:

1) High output levels. This means that modest amplifiers or receivers will be able to produce acoustical levels normally associated with amplifiers with substantially more rated power.

2) Smooth, extended response. The JBL Series 12 mm pure titanium dome tweeter, polymer laminated cone drivers and carefully designed dividing network deliver clear, crisp, quality sound.

3) Accurate time/phase response. Speakers in the JBL Series exhibit the same precise "turn-on, turn-off" characteristics of JBL's larger home and studio loudspeaker systems. This means more accurate realization of the high frequency detail in today's digital recordings.

4) Accurate stereo imaging. The in-line component arrays on the baffle ensure the best possible stereo imaging for listeners both on axis and off.

Placement

For the best stereo reproduction, the two loudspeaker systems should be placed an equal distance from your listening position and separated so that the angle between them, at the listening position, is between 40 and 60 degrees (see Fig. 1). For example, if your listening position is 8 to 12 feet (2.5 to 4.5 m) from each speaker, the two systems should be about 8 feet (2.5 m) apart.

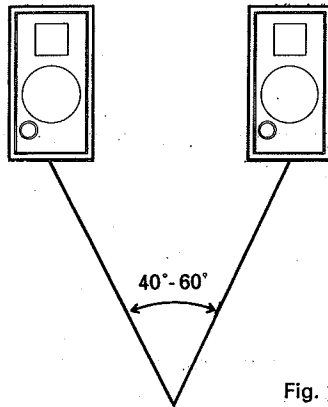

Fig. 1

Placing the loudspeakers in corners or against a wall will result in the strongest (but not necessarily the most accurate) bass. Compact systems will also benefit from placement on stands or shelves. For the best stereo imaging, we recommend that the systems be placed so that the high frequency transducers are as close as possible to the ear level of a seated listener. Every room is different — and there are different tastes. So don't hesitate to experiment on your own.

Connections

To connect the loudspeaker systems to the receiver or amplifier, use two-conductor insulated wire. Your JBL dealer can recommend suitable cables, or you can buy wire at most hardware stores. We recommend #18 AWG (1 mm diameter) wire as a minimum size. If your speakers are more than 30 feet (10 m) from your receiver or amplifier, use larger diameter wire. Connections are made at the terminals located on the back of the loudspeaker system, near the bottom edge. The terminals accept bare wire or banana plugs, either of which will provide easy, secure connections. To prepare the wire, strip approximately 1/2-inch (13 mm) of insulation. Each conductor is made up of fine strands of wire; twist the strands together. Push down on the button below the terminal and insert the wire through the hole (see Fig. 2).

For each channel, the red terminal on the loudspeaker should be connected to the red or (+) loudspeaker connection terminal on the receiver or amplifier.

The black terminal on the loudspeaker should be connected to the black or (-) loudspeaker connection terminal on the receiver or amplifier. Connecting the loudspeakers in this manner ensures that they will be in phase; that is, work together rather than in opposition. Connecting the loudspeakers out of phase will not damage them, but will result in less bass and poor imaging. Most two-conductor wire is color coded, or has a ridge on one of its insulating jackets, so that you can easily identify which wire is connected to which terminal (Fig. 2).

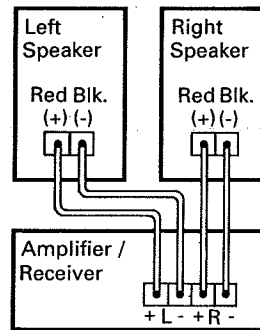

Fig.2

General Care

The grille is held in place by pins near the edges. To remove the grille, grasp it by both top and bottom edges and pull gently. To replace the grille, reposition it carefully and press gently at the corners. Do not push on the center area of the grille.

The loudspeaker enclosure may be cleaned with a slightly damp cloth. The grille may be gently vacuumed, and stains can be removed with an aerosol cleaner following the manufacturer's instructions. Never use any solvents to clean any part of the system.

Service

Should your loudspeaker ever need service, return it to the JBL dealer from whom it was purchased. If for some reason this is impractical, write directly to the JBL Customer Service Department, describing the problem as fully as possible. Do not return products to the JBL factory without prior authorization.

Technical Specifications

	JBL2500	JBL2600	JBL2800	JBL3800	JBL4800
High Frequency Transducer	12 mm titanium dome	12 mm titanium dome	12 mm titanium dome	12 mm titanium dome	12 mm titanium dome
Low Frequency Transducer	5.25" high polymer laminate	6.5" high polymer laminate	8" high polymer laminate	8" high polymer laminate	10" high polymer laminate
Midrange Transducer	—	—	—	5" high polymer laminate	5" high polymer laminate
Crossover Frequency	3 kHz	3 kHz	2.5 kHz	800 Hz 4.5 kHz	800 Hz 4.5 kHz
Frequency Response (-6 dB)	70 Hz to 23 kHz	45 Hz to 23 kHz	40 Hz to 23 kHz	35 Hz to 23 kHz	35 Hz to 23 kHz
Sensitivity (1 Watt/1 meter)	88 dB	89 dB	89 dB	89 dB	91 dB
Nominal Impedance	8 Ohms	8 Ohms	8 Ohms	8 Ohms	8 Ohms
Recommended Amplifier Power*	10 to 80 Watts	10 to 100 Watts	10 to 125 Watts	10 to 150 Watts	10 to 150 Watts
External Dimensions (HxWxD)	12" x 7.25" x 6.375" 305 mm x 191 mm x 162 mm	17" x 9" x 8.375" 432 mm x 229 mm x 213 mm	22.5" x 11" x 10" 572 mm x 279 mm x 259 mm	32" x 11" x 10" 813 mm x 279 mm x 259 mm	34½" x 13" x 11¼" 876.3 mm x 330.2 mm x 298 mm
Weight (each)	8 lbs. (3.6 kgs.)	12 lbs. (5.4 kgs.)	20 lbs. (9.0 kgs.)	29 lbs. (13.2 kgs.)	36 lbs. (16.3 kgs.)

*Undistorted continuous power per channel.



JBL Consumer Products Inc.

JBL in the USA
240 Crossways Park West
Woodbury, N.Y. 11797

Printed in USA
All contents
1988 JBL Consumer Products Inc.
Part JBL Series #70737